

JBC

www.jbctools.com



Control Unit for Automation

Ref. UCR245-5A/UCR470-5A

Packing List

The following items should be included:

Control Unit for Automation 1 unit
Ref. UCR245-5A
UCR470-5A



Tool Cable 3m 1 unit
Ref. 0021403



Power Cord 1.5m 1 unit
Ref. 0009401



Communications Cable 3m 1 unit
Ref. 0020261



Manual 1 unit
Ref. 0021384



Functions

There are up to 44 functions to control the station, such as:

- Temperature Control
- Sleep and Hibernation Control
- Station Status
- Error Information
- Counters (Working Time, Sleep, Hibernation...)

**Download the Robot Communication Protocol for UCR unit available at*
www.jbctools.com/jbcsoftware.html

Features

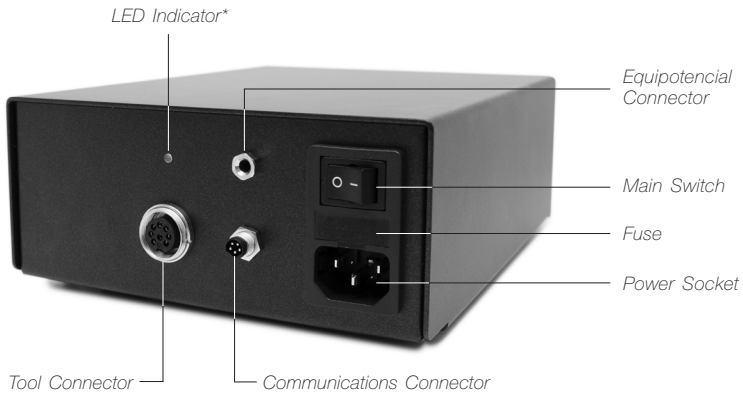

*LED Indicator:
 · Blue: equipment powered
 · Green: equipment working
 · Red blinking: error. See table below for more info.

Errors

In case of error, a red light flashes a certain number of times, indicating an error number as shown in the table below:

N° Error	Description	Solution
1 times	Short-circuit	Replace Cartridge
2 times	Open circuit	Replace Cartridge
3 times	Tool not accepted	Check if the tool is compatible with the Contron Unit
4 times	Tool detection error	Check the tool
6 times	Current usage leads to overloading	Due to overload wait until the device has cooled down
7 times	Short-circuit	Check if the cartridge is compatible with the Control Unit
12 times	Memory error	Reset the Control Unit

If the error persists, contact with JBC technical service.

Connection

- The UCR can be connected to a PLC by a five-pin Communications Cable (Ref. 0020261).
- For a proper connection, it is necessary to connect only three cables to the corresponding 3 pins at a typical DB9 male connector (PLC or computer).
- Download the Robot Communication Protocol at www.jbctools.com

Communications Cable

Ref. 0020261

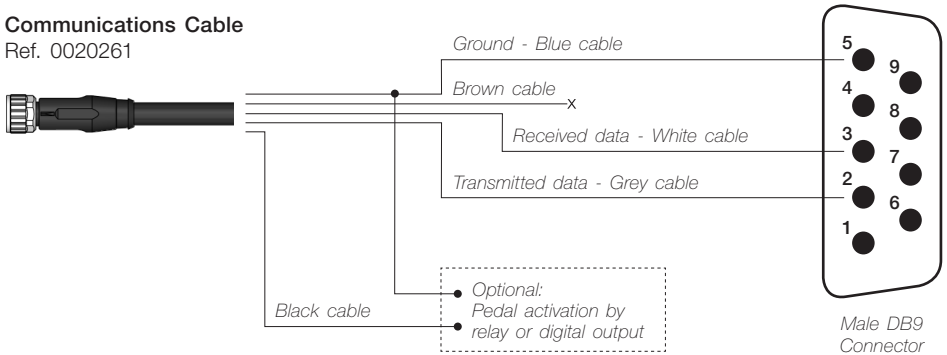

For detailed information about pin distribution see following table:

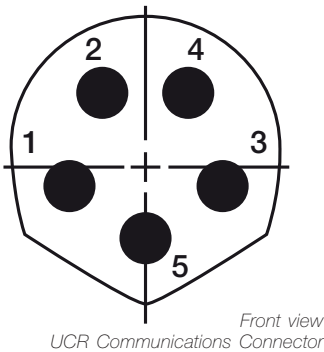

Pin Distribution		
Pin	Color	Description
1	Brown	Not used
2	White	Serial input: RS232 RX
3	Blue	Common reference: GND for RS232 and witch
4	Black	Switch input: 0V or 24V to start feeding. Leave it open to stop
5	Grey	Serial output: RS232 TX

Compatibility

The UCR can be used with both tools **TR** and **TRA** and its Cartridge Ranges **R245** and **R470** respectively. Connect any of those Soldering Irons with the provided Tool Cable (Ref. 0021403). See the table below to check the compatibility of the devices.



Ref. TR245-A



Ref. TRA245-A

Control Unit	Cartridge Range		Soldering Irons				Cartridge Stand	
	R245	R470	TR245	TR470	TRA245	TRA470	CS2R245	CS2R470
UCR245	●		●		●		●	
UCR470		●		●		●		●

RBA, SFR, GSFR and CLMR are compatible with R245 and R470 ranges.

Dimensions

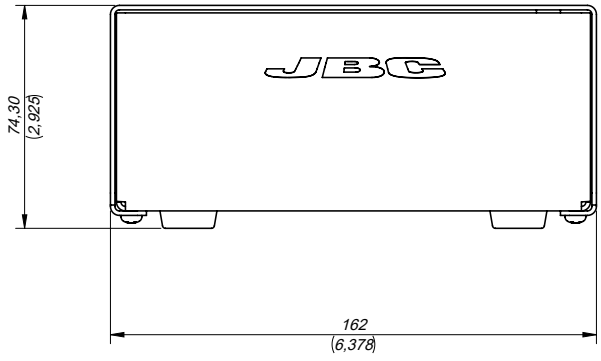
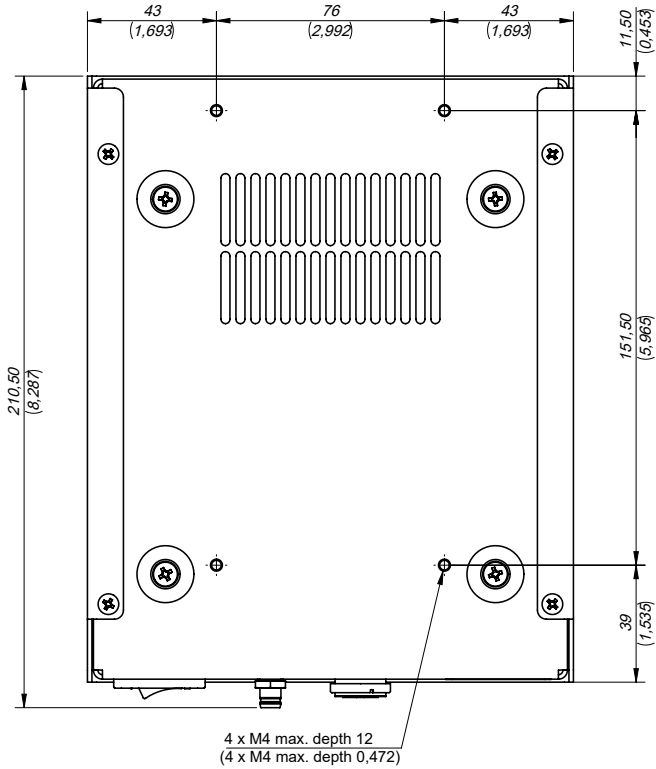

mm
(in)

Work Place Example

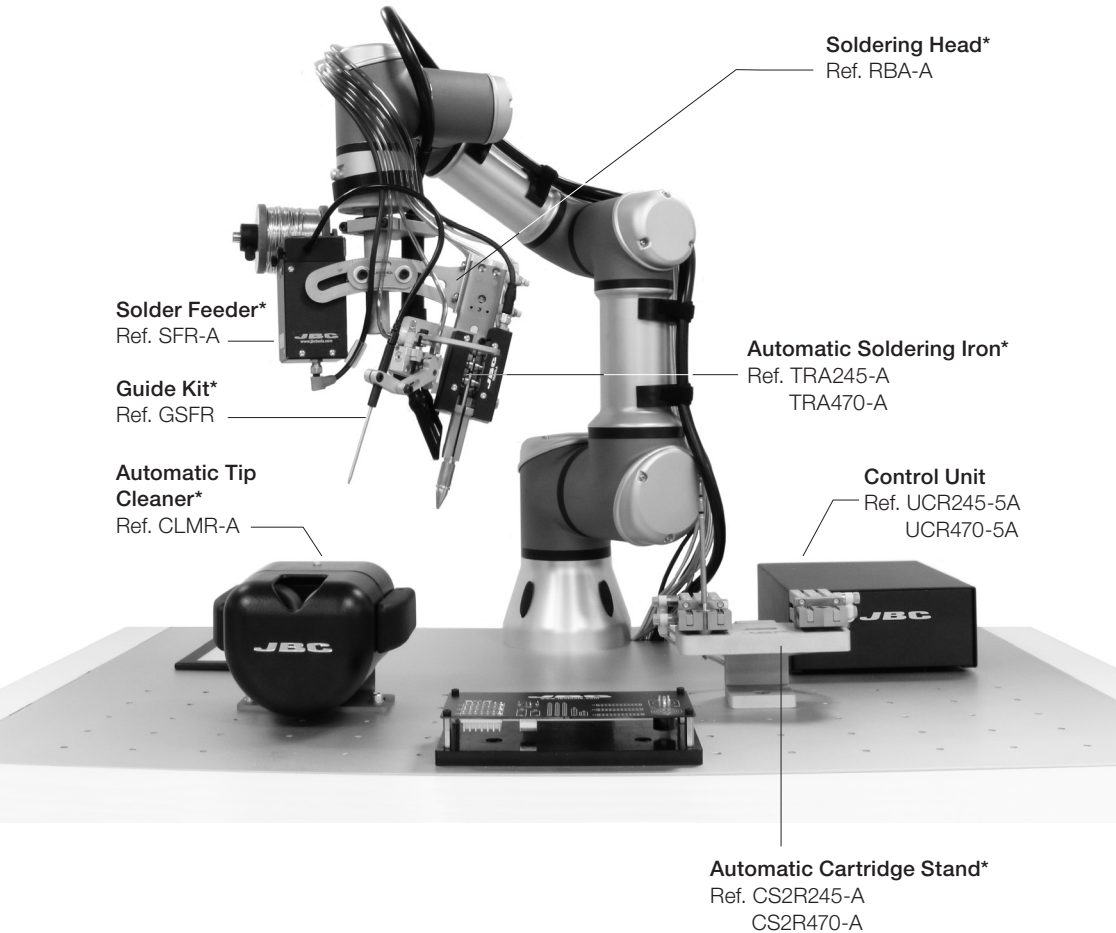

**Not included, sold separately*

Maintenance

- Before carrying out maintenance, always allow the equipment to cool down.
- Periodically check all cables and tube connections.
- Replace a blown Fuse as follows:

1. Pull off the Fuse Holder and remove the Fuse. If necessary, use a flat screwdriver to lever it off.

2. Insert the new Fuse into the Fuse Holder and return it to the station.

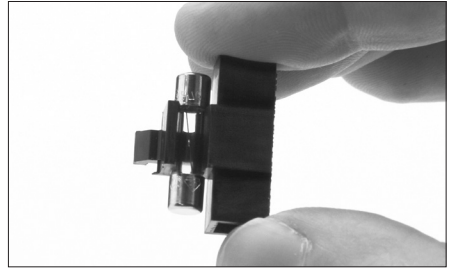

- Replace any defective or damaged pieces. Only use original JBC spare parts.
- Repairs should only be performed by a JBC authorized technical service.

Safety



It is imperative to follow safety guidelines to prevent electric shock, injury, fire or explosion.

- Do not use the device for any purpose other than soldering or rework. Incorrect use may cause fire.
- The main cable must be plugged into approved bases. Make sure that it is properly grounded before use. When unplugging it, hold the plug, not the wire.
- The temperature of accessible surfaces may remain high after the device is turned off. Handle with care.
- Do not leave the appliance unattended while it is on.
- Be sure that the power supply is disconnected before changing any spare part.
- Do not cover the ventilation grills. Heat can cause inflammable products to ignite.
- Heat can cause inflammable products to ignite even when not visible.
- Avoid flux coming into contact with skin or eyes to prevent irritation.
- Be careful with the fumes produced when soldering.
- Keep your workplace clean and tidy. Wear appropriate protection glasses and gloves when working to avoid personal harm.
- Utmost care must be taken with liquid tin waste which can cause burns.

有害物质含量表

产品中有害物质的名称及含量

部件名称	有害物质					
	铅(Pb)	汞(Hg)	镉(Cd)	六价铬 (Cr(VI))	多溴联苯 (PBB)	多溴二苯醚 (PBDE)
烙铁头	○	○	○	○	○	○
手柄	○	○	○	○	○	○
电源线	○	○	○	○	○	○
主机	○	○	○	○	○	○
电源插座	○	○	○	○	○	○
保险丝	○	○	○	○	○	○
主开关	○	○	○	○	○	○
电位连接	X	○	○	○	○	○
变压器	○	○	○	○	○	○
线路板	X	○	○	○	○	○

○ 表示该有害物质在该部件所有均质材料中的含量均在GB/T 26572 规定的限量要求以下。
 X 表示该有害物质至少在该部件的某一均质材料中的含量超出GB/T 26572 规定的限量要求。

Specifications

UCR245-5A 85 - 265V 50/60Hz. Input fuse: 2A. Output: 22V.

UCR470-5A 85 - 265V 50/60Hz. Input fuse: 4A. Output: 42V.

- Net Weight: 2.20 kg (4.9 lb)
- Dimensions: 210 x 162 x 75 mm (8.3 x 6.4 x 3.0 in)
- Output Peak Power (on UCR245-5A): 160W
- Output Peak Power (on UCR470-5A): 250W
- Temperature Range: 90 - 500 °C (190 - 932 °F)
- Idle Temp. Stability (still air): ± 1.5 °C / ± 3 °F
- Tip to ground resistance: < 2 ohms
- Tip to ground voltage: < 2mV RMS
- Ambient operating temp: 10 - 40 °C (50 - 104 °F)
- Connections: Communications: M8-5pins
Tool: M16-8pins

Complies with CE standards.
ESD protected housing.

JBC

Warranty

JBC's two-year warranty covers this equipment against all manufacturing defects, including the replacement of defective parts and labour.

Warranty does not cover product wear or misuse.

In case of any manufacturing defect, the equipment must be returned, postage paid, to the dealer where it was purchased. **Please, register your product within 30 days of purchase in www.jbctools.com/productregistration.**



This product should not be thrown in the garbage.

In accordance with the European directive 2002/96/EC, electronic equipment at the end of their life must be collected and returned to an authorized recycling facility.



Manual in other languages available on our website

www.jbctools.com