



www.jbctools.com

Robot Communication Protocol

Programmer's Guide

INDEX

1. Protocol Station-Robot	3
2. Physical Layer (PHL)	3
3. Data Link Layer (DLL)	4
3.1. Description of frame fields:	5
3.2 Description of connection:	5
3.3 Description of frame reception:	6
4. Application Layer (APL)	7
4.1 List of tools (tools)	7
4.2 List of Ports	7
4.3 List of tool errors	7
4.4 List of station errors	8
4.5 List of communication errors	8
4.6 List of the tool status	8
4.7 List of commands	9
4.8 Frames descriptions	10
4.8.1 Read select temperature (RSTx)	10
4.8.2 Write select temperature (WSTx)	10
4.8.3 Read tip temperature (RTTx)	10
4.8.4 Read port power (RPPx)	10
4.8.5 Read port error (RPEx)	10
4.8.6 Read port status (RPSx)	10
4.8.7 Write port status (WPSx)	10
4.8.8 Read connect tool (RCTx)	10
4.8.9 Read enter delay time sleep/hibernation (REDx)	11
4.8.10 Read adjust temp (RAxy)	11
4.8.11 Write adjust temp (WAXy)	11
4.8.12 Read sleep temperature (RSxy)	11
4.8.13 Write sleep temperature (WSxy)	11
4.8.14 Read sleep delay (RDxy)	11
4.8.15 Write sleep delay (WDxy)	11
4.8.16 Read hibernation delay (RHxy)	11
4.8.17 Write hibernation delay (WHxy)	12
4.8.18 Read transistor temperature (RQTx)	12
4.8.19 Read higher temperature alarm (RHAx)	12
4.8.20 Write higher temperature alarm (WHAx)	12
4.8.21 Read lower temperature alarm (RLAx)	12
4.8.22 Write lower temperature alarm (WLAx)	12
4.8.23 Read higher delay alarm (RHDx)	12
4.8.24 Write higher delay alarm (WHDx)	12
4.8.25 Read lower delay alarm (RHDx)	13
4.8.26 Write lower delay alarm (RHDx)	13
4.8.27 Read temperature alarm (RTAx)	13
4.8.28 Read station model name (RSMN)	13
4.8.29 Read maximum temperature (RMAT)	13
4.8.30 Write maximum temperature (VMAT)	14
4.8.31 Read minimum temperature (RMIT)	14
4.8.32 Write minimum temperature (WMIT)	14
4.8.33 Read station error (RSER)	14
4.8.34 Read transformer temperature (RTT)	14
4.8.35 Write reset station parameters (WRSP)	14
4.8.36 Read counter plugged hours (RCPx)	15
4.8.37 Read counter no tool hours (RCNx)	15
4.8.38 Read counter sleep hours (RCSx):	15
4.8.39 Read counter hibernation hours (RCHx)	15
4.8.40 Read counter work hours (RCWx)	15
4.8.41 Read counter sleep (RCCx)	15
4.8.42 Read counter desold (RCDx)	15

1. PROTOCOL STATION - ROBOT

To connect the JBC stations to a PC, the following communication protocol is developed, which is divided in 3 levels or layers:

- Application Layer
- Data Link Layer
- Physical Layer

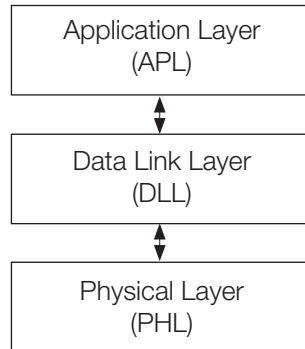

2. PHYSICAL LAYER (PHL)

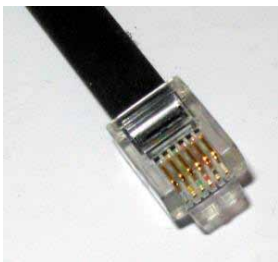

To connect the robot to the JBC station it is used a micro of communications from the manufacturer freescale, specifically the K60.

It must be previously configured on your computer, and once connected it must not allow to change parameters from the equipment unless the connection is aborted. In addition it can not allow new connections. To enter it is needed the express request of the user by entering to station settings and activating the robot mode, which is Control mode's type in this case.

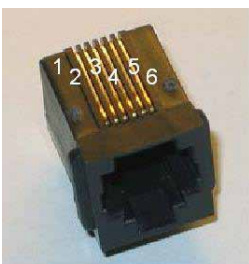

Physically it is type RS-232 with RJ12 connector (RJ-11, only 4 pins are used) and configuration: speed from 1200 to 500000 bps; 8 bits of data; even parity, odd parity or no parity; and 1 or 2 bits of stop (e.g. 19200-8E1). See the following pin distribution:

Pin	Description
1	NC
2	GND
3	Tx
4	Rx
5	GND
6	NC

The equipment configuration is DCE type and the robot configuration is DTE type, so that the connection cable can be direct. Anyway, you can reverse the connection type by turning the connection of one of the ends of the RJ-12 cable.

To enter it is needed the express request of the user by entering to station settings and activating the robot mode, which is Control mode's type in this case.

This type of connection does not need to maintain the connection, ie, the connected robot can set a temperature and not send any order more. The equipment remains with the last configured status awaiting new orders.

2.1 Possible configurations

Speed of transmission:

Number	Description
00h	1200 bps
01h	2400 bps
02h	4800 bps
03h	9600 bps
04h	19200 bps
05h	38400 bps
06h	57600 bps
07h	115200 bps
08h	230400 bps
09h	250000 bps
0Ah	460800 bps
0Bh	500000 bps

Parity:

Even
Odd
None

Stop Bits:

1 bit
2 bits

3. DATA LINK LAYER (DLL)

The frame format is the following, in which the field data may or may not depending on the type of frame. Furthermore the address fields may or may not appear depending on if has been activated sending / receiving with address:

- With no address

Start	Control header	Control code	Data	Stop	Check
1 byte	1 byte	3 bytes	0 ó 5 bytes	1 byte	1 byte
STX	'R', 'W', 'A', 'N'	"code"	"-9999" to "99999"	ETX	BCC

- With address

Start	Source address	Target address	Control header	Control code	Data	Stop	Check
1 byte	2 bytes	2 bytes	1 byte	3 bytes	0 ó 5 bytes	1 byte	1 byte
STX	"00" to "99"	"00" to "99"	'R', 'W', 'A', 'N'	"code"	"-9999" to "99999"	ETX	BCC

Everything is sent in ASCII code.

The Data field can be either visible or not. When visible, it is shown in five digits/characters.

Depending on the Control Header field, the following occurs:

- **R:** If an order for reading is sent, the data field is not shown.
- **W:** If an order for writing is sent, the data field appears.
- **A:** If an answer to a reading order is sent, the data field appears. If it is an answer to a written order the data field does not appear.
- **N:** If an answer of non-conformity is sent, the data field appears indicating the type of error.

3.1 Description of frame fields

- **Start:** This corresponds to the character STX of ASCII code (0x02). Start of transmission.
- **Source address:** Information's source address , the address range is from "00" to "99".
- **Target address:** Information's destination address, the address range is from "00" to "99".
- **Control:** This describes the frame function
 - Control header:
 - » **R:** Reading code (read)
 - » **W:** writing code (write)
 - » **A:** Correct frame code (ACK = acknowledgement)
 - » **N:** incorrect frame code (NAK = negative acknowledgement)
 - Control code: This describes the frame function.
- **Data:** Data sent is in ASCII code. This is shown in five digits. First tens of thousands are sent and successively to the last in units i.e. in order to send 12345, you first send `1`, and finally `5`. If the number contains a negative sign, this will be shown as an ASCII character `.` and placed at tens of thousands position, so that the lowest number that can be transmitted is -0050. If the number has less than five digits, e.g. 375, then zeros will be placed before it like "00375".
- **Stop:** This corresponds to the character ETX of ASCII code (0x03). End of transmission.
- **Check:** This is obtained by calculating the logic function XOR for the whole frame excluding the BCC. This is an error check.

3.2 Description of connection

Connection is selected from the station by activating the Robot mode. The equipment will only respond to instructions from the RS232 connection. This type of connection does not have an initial connection stage or a time-out to control the connection. It can only be activated and deactivated from the station.

3.3 Description of frame reception

Every frame that the robot sends to JBC equipment is evaluated at "data layer link (DLL)". To know if the received frame is correct or not if: it starts with STX + finishes with ETX + correct BCC + correct length. Once you have checked this is correct, the information is sent to application level (APL) and this will answer with a frame according to what is requested. Or else it is the layer link which answers with a frame of the type NACK.

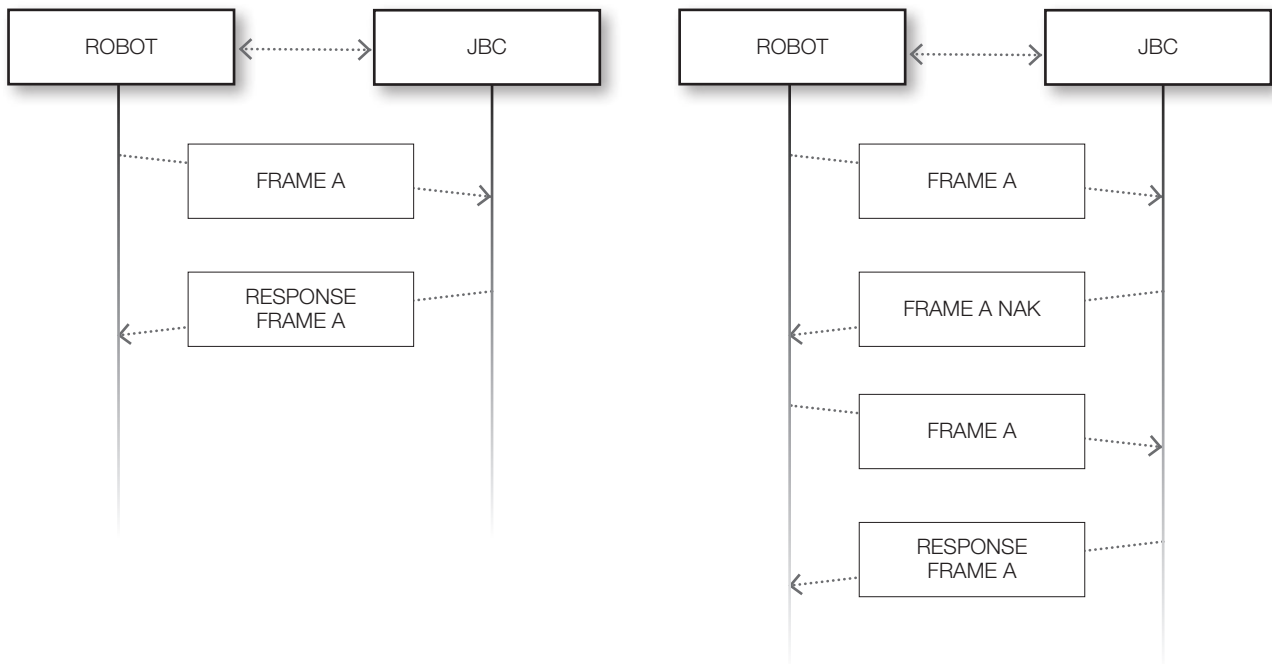

The number of repetitions followed by erroneous frames is determined by the Robot. The JBC equipment does not expect an ACK from the information the Robot sends. If the Robot receives a frame with errors, it can not ask this to be resent, so that it only can repeat everything once again..

4. APPLICATION LAYER (APL)

The application layer offers several services through order-answer type. The communication always begins in the ROBOT and the UC destination responds with a frame answer.

The data is always in ASCII five digit bytes.

- Temperatures are always shown in °C
- The power is given as in thousands of the theoretical maximum power station [%] without decimals.

A list of other kinds of data follows:

When the equipment is connected to the Robot, the tools ignore the sleep mode and the stand extractor. The tool status is decided by the Robot. Neither do the temperature nor temperature levels regulators work.

4.1 List of tools (tools)

Number	Description
0	Without tool
1	T210
2	T245 / T470 (only HDE station)
3	PA
4	HT
5	DS
6	DR
7	NT105
8	NP105

4.2 List of Ports

Number	Description
01h	Port 1
02h	Port 2
03h	Port 3
04h	Port 4

4.3 List of tool errors

Number	Description
00000	OK
00001	Short-circuit
00002	Short-circuit non-recoverable, equipment should be restarted
00003	Open circuit
00004	No tool
00005	No tool accepted
00006	Tool detection
00007	Stop due by maximum powers (Not implemented)
00008	Stop due by overload (MOS)
00009	Warning overload (MOS)

4.4 List of station errors

Number	Description
00000	OK
00001	Stop by overload (TRAFO)
00002	Temperature Sensor
00003	Memory
00004	Mains Frequency
00005	Station model
00006	Not connected MCU Tools
00007	Warning overload (TRAFO)

4.5 List of Communications errors

Number	Description
00001	BCC error (frame error when doing the sum check)
00002	Format error (format is not correct, i.e. incorrect size)
00003	Out of range (modifying value out of limit)
00004	Control error (control code not accepted)
00005	Control mode (you must control the equipment, mode robot)
00006	Station model error (station unknown)
99999	Undefined (error not defined)

4.6 List of tool status

The units digit indicates the status of the tool.

Number	Description
00000	No stand
00001	Stand, it still has not gone into sleep mode (delay)
00002	Sleep
00003	Hibernation

The tens digit indicates the extractor status.

Number	Description
00000	Extractor OFF
00010	Extractor ON

The hundreds digit indicates the desolderer status.

Number	Description
00000	Desoldering OFF
00100	Desoldering ON

4.7 List of commands

Code	Description
RSTx	Read select temperature + port
WSTx	Write select temperature + port
RTTx	Read tip temperature + port
RPPx	Read port power + port
RPEx	Read port error + port
RPSx	Read port status + port
WPSx	Write port status + port
RCTx	Read connect tool + port
REDx	Read enter delay time (sleep-hibernation) + port
RAxy	Read adjust temp + port + tool
WAxy	Write adjust temp + port + tool
RSxy	Read sleep temperature + port + tool
WSxy	Write sleep temperature + port + tool
RDxy	Read sleep delay + port + tool
WDxy	Write sleep delay + port + tool
RHxy	Read hibernation delay + port + tool
WHxy	Write hibernation delay + port + tool
RQTx	Read transistor temperature + port
RHAx	Read higher temperature alarm + port
WHAx	Write higher temperature alarm + port
RLAx	Read lower temperature alarm + port
WLAx	Write lower temperature alarm + port
RHDx	Read higher delay alarm + port
WHDx	Write higher delay alarm + port
RLDx	Read lower delay alarm + port
WLDx	Write lower delay alarm + port
RTAx	Read temperature alarm + port
RSMN	Read station model name
RMAT	Read maximum temperature
WMAT	Write maximum temperature
RMIT	Read minimum temperature
WMIT	Write minimum temperature
RSER	Read station error
RTT	Read transformer temperature
WRSP	Write reset station parameters (Factory Default)
WRST	Write station reset
RCPx	Read counter plugged hours + port
RCNx	Read counter no tool hours + port
RCSx	Read counter sleep hours + port
RCHx	Read counter hibernation hours + port
RCWx	Read counter work hours + port
RCCx	Read counter sleep + port
RCDx	Read counter desold + port

4.8 Frames descriptions

4.8.1 Read select temperature (RSTx)

To read the selected temperature, you need to replace the 'x' with the number of the destination port in ASCII, for example, "RST3".
The equipment answers with an "ASTx" as the control field, as in the example "AST3".
The data field will contain the requested information.
Table 4.2 lists the number of available ports.

4.8.2 Write select temperature (WSTx)

To modify the selected temperature, the 'x' should be replaced with the destination port in ASCII, for example "WST3".
Equipment answers with an "ASTx" as the control field, in the example "AST3".

4.8.3 Read tip temperature (RTTx)

To read the real tip temperature, the 'x' must be replaced with the number of the destination port in ASCII, for example, "RTT3".
The equipment answers with an "ATTx" as the control field, as in the example "ATT3".
Data field will contain the requested information.

4.8.4 Read port power (RPPx)

To read the power supplied to the tool, the 'x' must be replaced with the number of destination port in ASCII, for example "RPP3".
The equipment answers with an "APPx" as the control field, in the example "APP3".
Data field will contain the requested information.

4.8.5 Read port error (RPEx)

To read the port error, the 'x' must be replaced with the number of the destination port in ASCII, for example "RPE3".
Equipment answers with an "APEx" as the control field, in the example "APE3".
Field data will contain the requested information.

4.8.6 Read port status (RPSx)

To read the port status, the 'x' must be replaced with the number of the destination port in ASCII, for example "RPS3".
The equipment answers with an "APSx" as the control field, in the example "APS3".
Control field will contain the requested information. (See 4.6 List of tool status)

4.8.7 Write port status (WPSx)

To modify the port status, the 'x' must be replaced with the number of the destination port in ASCII, for example "WPS3".
The data field will contain the value you need to modify. (See list of tool status)
The only permitted values of this table are 00000 – 00001 since entering sleep or hibernation mode will depend on the parameters programmed in the station (delay).
The equipment answers with an "APSx" as the control field, as in the example "APS3".
When the equipment is connected to a robot, the tools ignore the sleep mode and the stand extractor, the tool status is decided by the robot.

4.8.8 Read connect tool (RCTx)

To read the connected tool, the 'x' must be replaced with the number of the destination port in ASCII, for example "RCT3".
The equipment answers with an "ACTx" as the control field, as in the example "ACT3".
The data field will contain the requested information.

4.8.9 Read enter delay time sleep/hibernation (REDx)

To read the delay time in seconds before going into sleep or hibernation mode, the 'x' must be replaced with the number of the destination port in ASCII, for example, "RED3".

The equipment answers with an "AEDx" as the control field, as in the example "AED3".

The data field will contain the requested information.

4.8.10 Read adjust temp (RAxy)

To read the tool adjustment temperature, the 'x' must be replaced with the destination port in ASCII, and 'y' with the specific tool. For example "RA32", port 3 and tool 2 (T245).

The equipment answers with an "AAxy" as the control field, in the example "AA32".

The data field will contain the requested information.

4.8.11 Write adjust temp (WAxy)

To modify the adjustment of the temperature, the 'x' must be replaced with the number of destination port in ASCII, and 'y' with the specific tool. For example "WA32", port 3 and tool 2 (T245).

The equipment answers with an "AAxy" as the control field, in the example "AA32".

4.8.12 Read sleep temperature (RSxy)

To read sleep temperature of the tool, the 'x' must be replaced with the number of destination port in ASCII, and 'y' by the specific tool. For example "RS32", port 3 and tool 2 (T245).

The equipment answers with an "ASxy" as the control field, in the example "AS32".

The data field will contain the requested information.

4.8.13 Write sleep temperature (WSxy)

To modify the sleep temperature, the 'x' must be replaced with the number of destination port in ASCII, and 'y' with the specific tool.

For example "WS32", port 3 and tool 2 (T245).

The equipment answers with an "ASxy" as the control field, in the example "AS32".

4.8.14 Read sleep delay (RDxy)

To read sleep delay of the tool, the 'x' must be replaced with the number of the destination port in ASCII, and 'y' with the specific tool. For example "RD32", port 3 and tool 2 (T245).

The equipment answers with an "ADxy" as the control field, in the example "AD32".

The data field will contain the requested information.

If received "99999" means the sleep mode is disabled.

4.8.15 Write sleep delay (WDxy)

To modify the sleep delay, the 'x' must be replaced with the number of the destination port in ASCII, and 'y' with the specific tool. For example, "WD32", port 3 and tool 2 (T245).

The equipment answers with an "ADxy" as the control field, in the example "AD32".

To disable the sleep mode, send "99999".

4.8.16 Read hibernation delay (RHxy)

To read the sleep delay temperature of the tool, the 'x' must be replaced with the number of destination port in ASCII, and 'y' with the specific tool. For example "RH32", port 3 and tool 2 (T245).

The equipment answers with an "AHxy" as the control field, in the example "AH32".

The data field will contain the requested information.

If received "99999" means the hibernation mode is disabled.

4.8.17 Write hibernation delay (WHxy)

To modify the hibernation delay, the 'x' must be replaced with the number of the destination port in ASCII, and 'y' with the specific tool. For example, "WH32", port 3 and tool 2 (T245).

The equipment answers with an "AHxy" as the control field, as in the example "AH32".

To disable the sleep mode, send "99999".

4.8.18 Read transistor temperature (RQTx)

To read the transistor temperature regulation, the 'x' must be replaced with the number of destination port in ASCII, for example "RQT3".

The equipment answers with an "AQTx" as the control field, in the example "AQT3".

The data field will contain the requested information.

4.8.19 Read higher temperature alarm (RHAx)

To read the higher temperature alarm, the 'x' must be replaced with the number of destination port in ASCII, for example "RHA3".

The equipment answers with an "AHAx" as the control field, in the example, "AHA3".

Data field will contain the requested information.

4.8.20 Write higher temperature alarm (WHAx)

To modify the higher temperature alarm, the 'x' must be replaced with the number of destination port in ASCII, for example "WHA3".

The equipment answers with an "AHAx" as the control field, in the example "AHA3".

4.8.21 Read lower temperature alarm (RLAx)

To read the lower temperature alarm, the 'x' must be replaced with the number of the destination port in ASCII, for example "RLA3".

The equipment answers with an "ALAx" as the control field, in the example "ALA3".

The data field will contain the requested information.

4.8.22 Write lower temperature alarm (WLAx)

To modify the lower temperature alarm, the 'x' must be replaced with the destination port number in ASCII, for example "WLA3".

The equipment answers with an "ALAx" as the control field, in the example "ALA3".

4.8.23 Read higher delay alarm (RHDx)

To read the delay for higher temperature alarm, the 'x' must be replaced by the number of destination port in ASCII of the request, for example "RHD3". The equipment answers with an "AHDx" as the control field, in the example, "AHD3".

Data field will contain the requested information in format "ss.cc" in ASCII, in which:

- ss: corresponds to the time in seconds.
- cc: corresponds to the time in hundredths of a second.

Examples:

- "01.60" → 1,6s
- "00.00" → 0s, when it exceeds the limit, the error is activated.
- "99999" → The alarm is disabled.

4.8.24 Write higher delay alarm (WHDx)

To modify the delay for higher temperature alarm, the 'x' must be replaced by the number of destination port in ASCII of the request, for example "WHD3". Data field will contain the information of the new delay in format "ss.cc" in ASCII, in which:

- ss: corresponds to the time in seconds.
- cc: corresponds to the time in hundredths of a second.

Examples:

- "01.60" → 1,6s
- "00.00" → 0s, when it exceeds the limit, the error is activated.
- "99999" → The alarm is disabled.

The equipment answers with an "ALDx" as the control field, in the example, "AHD3".

4.8.25 Read lower delay alarm (RLDx)

To read the delay for lower temperature alarm, the 'x' must be replaced by the number of destination port in ASCII of the request, for example "RLD3". The equipment answers with an "ALDx" as the control field, in the example, "ALD3".

Data field will contain the requested information in format "ss.cc" in ASCII, in which:

- ss: corresponds to the time in seconds.
- cc: corresponds to the time in hundredths of a second.

Examples:

- "01.60" 1,6s
- "00.00" → 0s, when it exceeds the limit, the error is activated.
- "99999" → The alarm is disabled.
→

4.8.26 Write lower delay alarm (RLDx)

To modify the delay for lower temperature alarm, the 'x' must be replaced by the number of destination port in ASCII of the request, for example "WLD3". Data field will contain the requested information in format "ss.cc" in ASCII, in which:

- ss: corresponds to the time in seconds.
- cc: corresponds to the time in hundredths of a second.

Examples:

- "01.60" 1,6s
- "00.00" → 0s, when it exceeds the limit, the error is activated.
- "99999" → The alarm is disabled.
→

The equipment answers with an "ALDx" as the control field, in the example, "ALD3".

4.8.27 Read temperature alarm (RTAx)

To read the alarm flag, once you have read the flag this is deleted. The 'x' must be replaced with the number of the destination port in ASCII, for example "RTA3".

The equipment answers with an "ATAx" as the control field, in the example "ATA3".

The data field will contain the requested information.

The units digit contains the high temperature flag alarm

- '0' there is no alarm
- '1' the alarm has been on

The tens digit contains the low temperature alarm flag

- '0' there is no alarm
- '1' alarm has been on

4.8.28 Read station model name (RSMN)

To read the station model name.

The PC answers with the ASCII code associated to each character that makes up the station model, together with blanks to complete the five-character data field. Blank spaces will occupy the most significant bytes of the data field, as shown in the example: "DDR".

The equipment answers with an "ASMN" as the control field.

The data file will contain the requested information.

4.8.29 Read maximum temperature (RMAT)

To read the maximum working temperature of the station.

The equipment answers with an "AMAT" as the control field.

The data file will contain the requested information.

4.8.30 Write maximum temperature (WMAT)

This modifies the maximum working temperature of the station.

The equipment answers with an "AMAT" as the control field.

4.8.31 Read minimum temperature (RMIT)

To read the minimum working temperature of the station.
The equipment answers with an "AMIT" as the control field.
The data field will contain the requested information.

4.8.32 Write minimum temperature (WMIT)

It modifies the minimum working temperature of the station.
The equipment answers with an "AMIT" as the control field.

4.8.33 Read station error (RSER)

To read the station error.
The equipment answers with an "ASER" as the control field.
The data field will contain the requested information.

4.8.34 Read transformer temperature (RTT)

To read the temperature of the transformer.
The equipment answers with an "ATT" as the control field.
The Control field will contain the requested information.

4.9.35 Write reset station parameters (WRSP)

To reset the station parameters at factory values.
The equipment answers with an "ARSP" as the control field.

4.8.36 Read counter plugged hours (RCPx)

To read the connected-hours counter, the 'x' must be replaced with the number of destination port in ASCII of the request, for example "RCP3".
The equipment answers with an "ACPx" as the control field, in the example, "ACP3".
The data field will contain the requested information.

4.8.37 Read counter no tool hours (RCNx)

To read the hour counter without a tool, the 'x' must be replaced with the number of destination port in ASCII of the request, for example "RCN3".
The equipment answers with an "ACNx" as the control field, in the example "ACN3".
Data field will contain the requested information.

4.8.38 Read counter sleep hours (RCSx):

To read the counter of sleep hours, the 'x' must be replaced with the number of destination port in ASCII of the request, for example "RCS3".
The equipment answers with an "ACSx" as the control field, in the example "ACS3".
Data field will contain the requested information.

4.8.39 Read counter hibernation hours (RCHx)

To read the counter of hibernation hours, the 'x' must be replaced with the number of the destination port in ASCII of the request, for example "RCH3".
The equipment answers with an "ACHx" as the control field, in the example "ACH3".
Data field will contain the requested information.

4.8.40 Read counter work hours (RCWx)

To read the working hours counter, the 'x' must be replaced with the number of the destination port in ASCII of the request, for example "RCW3".

The equipment answers with an "ACWx" as the control field, in the example "ACW3".

The data field will contain the requested information.

4.8.41 Read counter sleep (RCCx)

To read the counter sleep cycles, the 'x' must be replaced with the number of the destination port in ASCII of the request, for example "RCC3".

The equipment answers with an "ACCx" as the control field, in the example "ACC3".

The data field will contain the requested information.

4.8.42 Read counter desold (RCDx)

To read the desoldering counter cycles the 'x' must be replaced with the destination port number in ASCII of the request, for example "RCD3".

The equipment answers with an "ACDx" as the control field, in the example "ACD3".

Data field will contain the requested information.

