



A Donaldson Company

A WORLD LEADER IN FUME EXTRACTION TECHNOLOGY

AD GoldSEAL + Cyclone

LASER

Last Updated on 05.02.2018



The complete solution for the extraction, filtration and recovery of precious metals.

The AD GoldSEAL + Cyclone is a dust extraction system designed for the jewellery industry that recovers and collects precious metals.

The metal particles are collected in an easy to remove tray and the HEPA filter can be incinerated to reveal the precious metal collected in the filtration process.

Automatic Flow control allows the user to pre-set correct air flow rates, for lower noise levels and allow further protection of the HEPA filter.

The Cyclone provides pre separation of precious metal, allowing easier efficient collection of precious metal from the collection pot and prolonging the life of the main filter.

Technology



HEPA filter



Automatic flow control (AFC) technology



Reverse flow air (RFA) technology



Multi voltage sensing (MVS) unit



ProTECT service plan



SureCHECK quality standard

Key features of the AD GoldSEAL + Cyclone

Reverse flow filter technology
Standard

Auto sensing voltage (90v - 257V) For global use
Standard

Removable collection tray
Standard

HEPA filtration
Standard

Lockable filter inside unit
Standard

Incinerable filter to recover maximum available gold
Standard

Tamper proof
Standard

24V Remote stop / start interface
Optional

Automatic flow control
Standard

Filter status warnings
Standard

High pressure turbine
Standard

Lockable unit
Standard

Filter box designed to aid removal of collected gold
Standard

Small footprint
Standard

Cyclone
Standard

Contact BOFA at <https://bofainternational.com/en/contact/>

<https://bofainternational.com/en/portal/datasheets/ad-goldseal-plus-cyclone/>





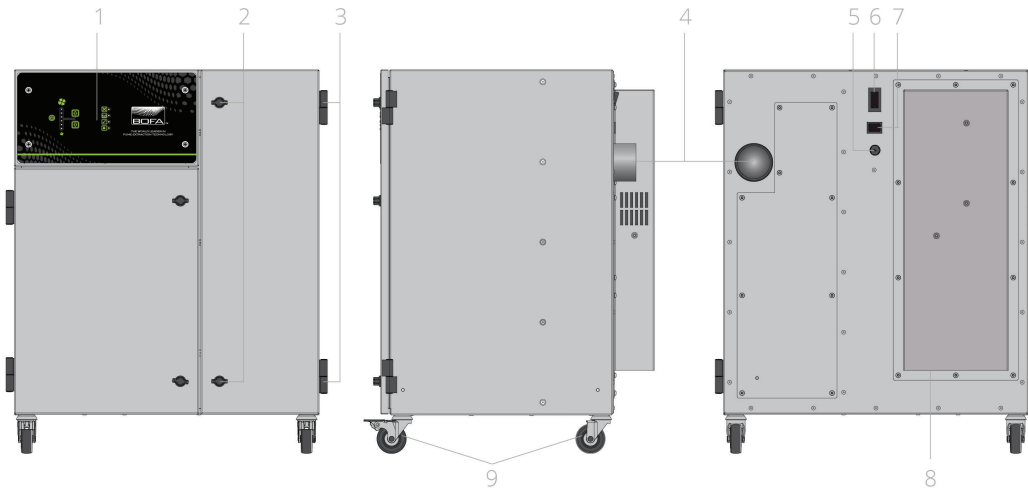

Technical specification

- 1. Control panel
- 2. Door latch
- 3. Hinges
- 4. Air inlet 75mm
- 5. Interface (optional)
- 6. Mains switch
- 7. Mains inlet
- 8. Exhaust
- 9. Castors



Airflow through filters

-  HEPA filter
-  Clean air
-  Contaminated air
-  Particulate

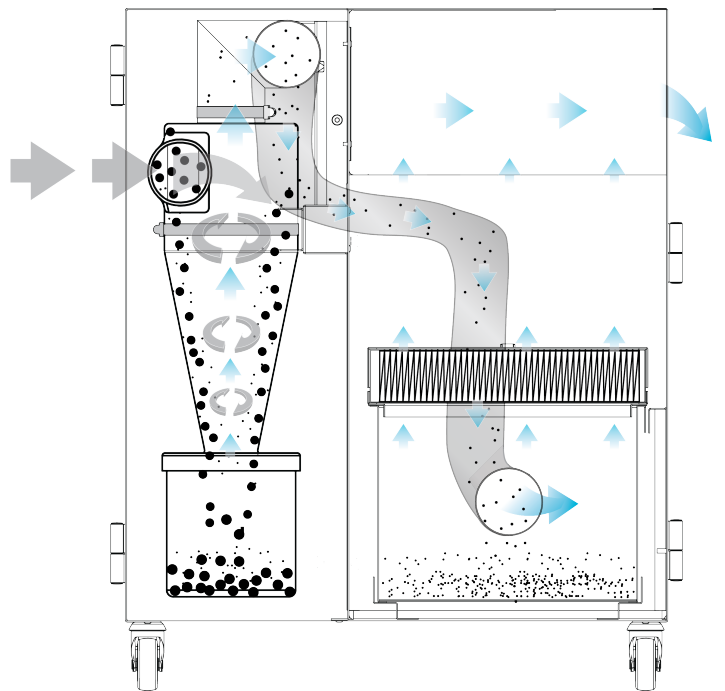

Technical data

	EU	US
Dimensions (HxWxD)	755 x 650 x 560mm	29.72 x 25.60 x 22.05"
Cabinet construction	Powder coated mild steel	Powder coated mild steel
Airflow / Pressure	267m ³ /hr / 96mbar	157cfm / 96mbar
Electrical data	115v - 230v 1ph 50/60Hz Full load current: 10 amps / 1.1kw	115v - 230v 1ph 50/60Hz Full load current: 10 amps / 1.1w
Noise level	< 70dBA (at typical operating speed)	< 70dBA (at typical operating speed)
Weight	54.7kgs	120lbs
Approvals	CE	CE

HEPA filter specifications

HEPA filter media	Glass fibre
HEPA media construction	Maxi pleat construction with webbing spacers
Filter efficiency	99.95% @ 0.3 microns

Unit part numbers

Model	Feature	Voltage	Part no.
AD GoldSEAL + Cyclone powder coated	-	115V - 230V	30811111-1824
AD GoldSEAL + Cyclone powder coated	24V Stop / Start	115V - 230V	180811111-1824

Replacement filter part numbers

Description	Part no.
HEPA filter	A1030352

Other languages

AD GoldSEAL + Cyclone
[French](#)

Datasheet correct at time of publishing.

Where applicable, the carbon used in BOFA units is capable of removing a wide range of VOC's, however it is the responsibility of the user to ensure the carbon is suitable for their application. For specific applications, please contact us for details.

Think before you print! Please consider the environment before printing this document.

